

# Molding Innovation

FEB. 2012

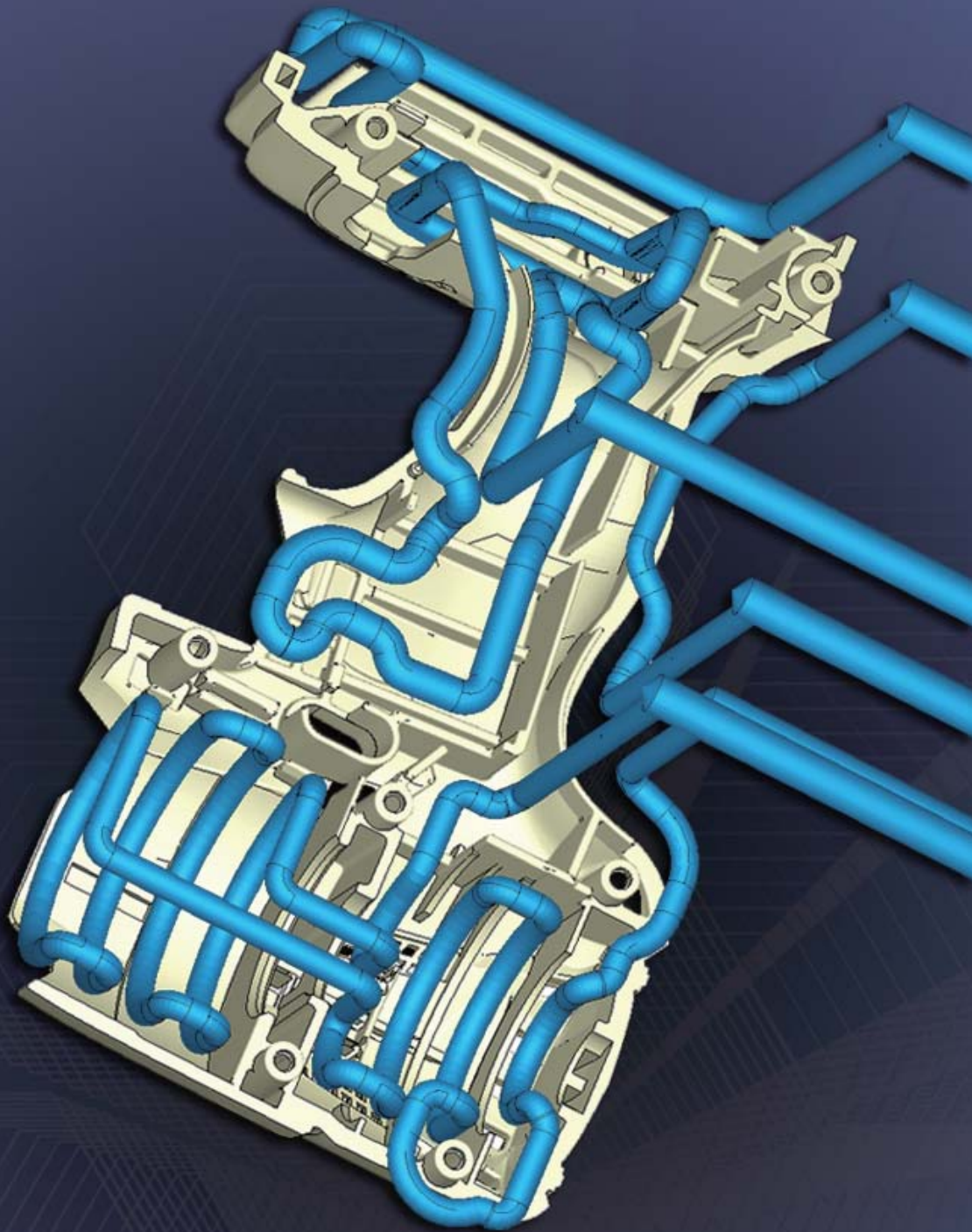

## **INSIDER**

- 1** Top Story  
A Cool Solution- Moldex3D R11.0 Debuts Conformal Cooling Design Validation and 3D Cooling Analysis
- 11** Tips & Tricks  
3D Cooling Channel Import is Now Available in R11.0

## **GO FOR SUCCESSFUL MOLDING**

- 13** Maximizing Cooling Effects with Moldex3D Conformal Cooling Solution- A Case Study of MATSUI MFG. CO., LTD.
- 18** Synergy of True & Full 3D Simulation and Conformal Cooling

## **Moldex3D**

**A Cool Solution- Moldex3D R11.0 Debuts Conformal Cooling Design Validation and 3D Cooling Analysis**

**Moldex3D**  
MOLDING INNOVATION

# A Cool Solution- Moldex3D R11.0 Debuts Conformal Cooling Design Validation and 3D Cooling Analysis

In the past few decades, several novel injection molding techniques have been developed in pursuit of better quality and cost savings. Cooling is the most dominant stage in injection molding in terms of quality and cycle time. Therefore, how to design an efficient cooling system is always critical. Among various cooling solutions, conformal cooling has gained importance due to proven success in cost and cooling time reduction.

CAE software can successfully assist in evaluating the effectiveness of cooling layout designs and verify potential design problems at early stage. For example, physical properties such as pressure, temperature, and flow velocity can be presented in three dimensional inside cooling channels. Users can detect potential design problems based on analysis results. In addition, through cooling time prediction, users will perceive the effect of cycle time on a cooling system.

With Moldex3D's latest technology in predicting flow behavior inside cooling channels, designers and molders can utilize additional results such as streamlines and velocity vectors to optimize their designs. Figure 1 shows the velocity vectors inside a twin-spiral cooling channel and Figure 2 shows the streamlines inside a baffle cooling system. All results are three-dimensional providing the best reliable information.. For more information regarding conformal cooling demonstrations and case studies, please go to our website [www.moldex3d.com](http://www.moldex3d.com) to find out more in-depths.

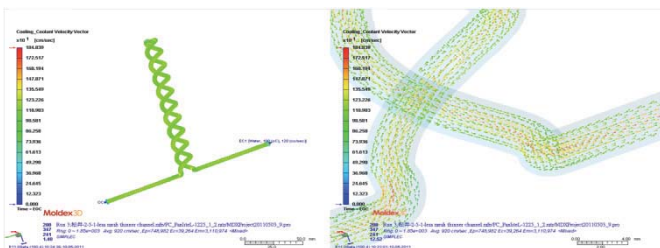

**Figure1.** Velocity vector inside a twin-spiral cooling channel



**Figure2.** Stream lines inside a baffle cooling channel

In this issue, we also include two technical papers regarding laser sintering and conformal cooling applications which offer more state-of-the-art information in this growing market.

- [Direct Metal Laser Sintering Technology Applications on Conformal Cooling System Development](#)
- [Introduction of Composite Technology, Combining Machining with Selective Laser Melting for Metal Powder Forming](#)

## Direct Metal Laser Sintering Technology Applications on Conformal Cooling System Development

Jack Wu

*EOS GmbH Electro Optical Systems*

Andrew Hsu

*CoreTech System Co., Ltd*

### Introduction of Direct Metal Laser Sintering (DMLS) Technology

With increasing product complexity but shorter development time, how to improve mold cooling efficiency to reduce cycle time has been an important issue in injection molding process. One crucial factor to reduce cooling time is a high efficiency cooling channel design. And conformal cooling is the solution. In addition, conformal cooling is also helpful in improving some product defects such as sink mark and warpage. By using some non-conventional methods such as laser sintering, cooling channels can get closer to the cavity surface than using traditional method. This resolves local heat accumulation problems and provides a more efficient cooling channel. Manufactured by EOS GmbH, the direct metal laser sintering (DMLS) machine can be utilized to compensate the insufficiency of traditional CNC and EDM tooling method. It can easily manufacture cooling channels with any geometry.

### Cooling efficiency comparison - conformal cooling channel vs. conventional cooling channel

The geometry of a conformal cooling channel is more complex than a conventional cooling channel. Thus, it is more difficult to manufacture through traditional tooling method. However, by using non-traditional manufacturing method such as DMLS, cooling system layout is not restricted. Conformal cooling channel offers a better cooling efficiency to lower the cycle time. In addition, due to the lower mold temperature difference, some product defects such as warpage and sink mark can be avoided. Product quality is thus improved effectively.

EOSINT M series is the DMLS equipment manufactured by EOS GmbH. The procedures of laser sintering start from melting metal powder by laser beams. Follow by that is a layer-by-layer additive forming step. At the end, the sintered part will be harden and milled to the final tool insert. The metal powder developed by EOS can be fully reused. And there are several options of the powder for each specific use.

As to cooling channel design, there are many research works related to optimization theory. Basically, cooling channel should be as close to the cavity as possible; however, mold strength is a great concern. There exist some experimental rules for cooling channel design. Figure 1 shows the relation among the three important design parameters.

Figure 2 shows a case from PEP. A conventional and a conformal cooling channel were compared with a 20 °C mold temperature drop and 20 seconds cycle time reduction. The product in Figure 3 is a give-away golf ball. It needs to be produced in large quantity (20 millions) with a low cost. Through DMLS tooling method, this four cavity tool took only 50 hours to build up while the productivity increased 20%.

### Moldex3D Molding Simulation on Conformal Cooling Channel Design Validation

DMLS is only a technique in manufacturing conformal cooling channels. The cooling system design itself is the crucial factor for success. But how can we validate the design? Molding simulators such as Moldex3D can help with an efficient and economic way. Through molding simulations, we can quickly understand the effects of cooling systems on cycle time and product quality. The simulation results provide useful indices for cooling system re-design. Using this kind of computer-assisted mold trial method can save mold development cost most effectively.

Figure 4 is a children cup case provided by EOS GmbH. In this case, a conventional baffle design was compared with a conformal cooling design (as shown in Figure 5).

Through Moldex3D simulation (Figure 6), we can see the mold temperature distribution range drops from 79~91°C (conventional) to 79~84°C(conformal). Since conformal cooling design keeps the same distance between cooling channel surface and cavity surface, the cooling rate differences at the part surface can be much smaller than a baffle design. Also, the heat spot can be relief further. According to the data from EOS, cycle time can be reduced by 42% if conformal cooling design was applied.

## Conclusion

The concept of conformal cooling is getting popular nowadays since its effect is significant. DMLS method can compensates the insufficiency of traditional CNC and EDM tooling method and manufacture complex cooling channels which traditional tooling method cannot reach.

Through molding simulators such as Moldex3D can effectively reduce actual mold trial times. It provides a quick tool for design validation in purposes of design optimization and cost reduction.

Contact: Jack Wu

EOS Area Sales Manager - China/Taiwan

Tel: (+886)3 657 6351

Email: <mailto:WuCH@eos.info>

## References

[1] Mike Shellabear, Joseph Weilhammer: Tooling Applications with EOSINT M.

In: EOS Whitepaper, Krailling, September 2007.

[2] Olaf Zöllner, Optimised mould temperature control.

In: ATI 1104 d (Application Technology Information), Plastics Business Group, Bayer AG, Leverkusen, 31.01.1999.

**Keyword:** DMLS, conformal cooling, injection molding.

## Acknowledgement

In appreciation of EOS GmbH to provide research report and figures.

Wall thickness of molded product (in mm)	Hole diameter (in mm)	Centerline distance between holes	Distance between center of holes and cavity
	b	a	c
0 - 2	4 - 8	2 - 3 x b	1.5 - 2 x b
2 - 4	8 - 12	2 - 3 x b	1.5 - 2 x b
4 - 6	12 - 14	2 - 3 x b	1.5 - 2 x b

Figure 1 Conformal cooling design rules

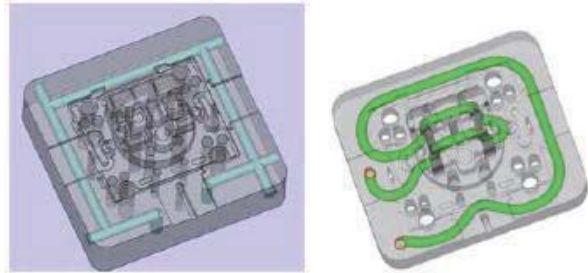

Figure 2 PEP case: conventional cooling design (left) and conformal cooling design (right)

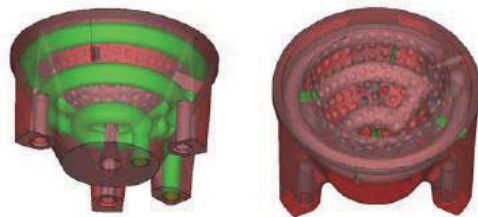

Figure 3 Golf ball mold insert with a conformal cooling channel design

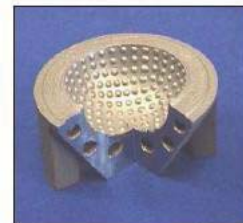

Figure 4 EOS children cup case

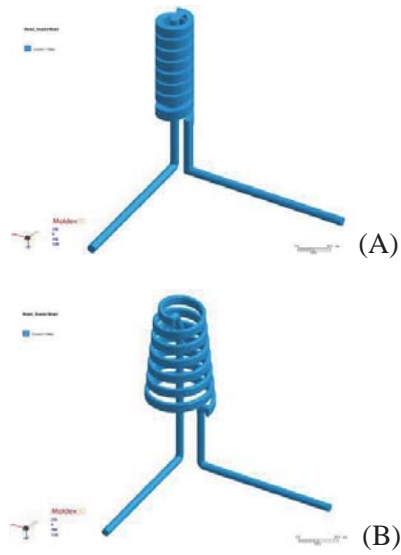

Figure 5 Baffle design (A) and conformal cooling design (B)

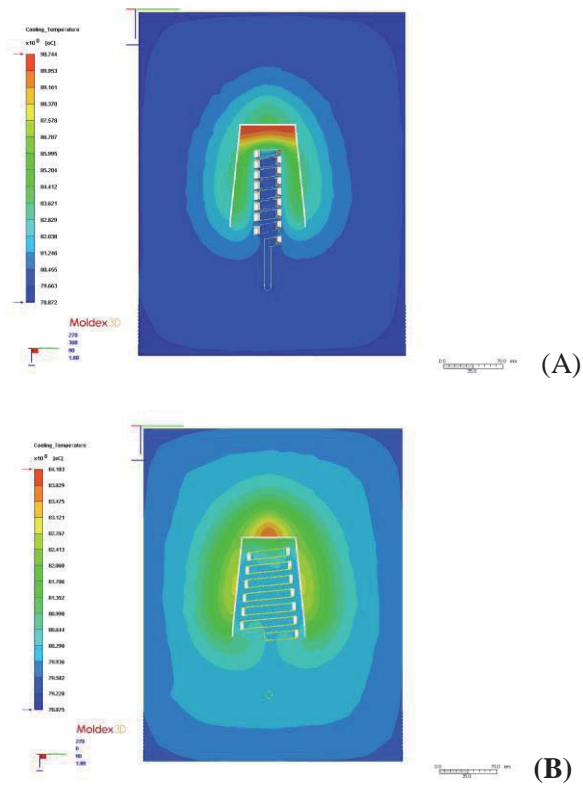

Figure 6 Mold temperature distributions at the end of cooling (A) baffle design (B) conformal design

## **Introduction of Composite Technology, Combining Machining with Selective Laser Melting for Metal Powder Forming**

**Yan Chin**

*Shanghai Matsui Machinery Co., Ltd*

**Andrew Hsu**

*CoreTech System Co., Ltd*

In recent years, in view of shortening product lifecycles, the rapid prototyping (RP) technology has been applied to the manufacturing of injection molds. For example, in Europe metal powder selective laser sintering (SLS) technology or selective laser melting (SLM) technology, which is originally one of the RP technologies, have been used for direct manufacturing of metal parts and further developed for the manufacturing of components of injection molds.

During the forming process based on the conventional selective laser melting (SLM) technology, the inherent defects during laser scanning, such as powder splashing in the bath, spheroidization, and powder sticking, may cause the shaped part to have dimensional inaccuracies and higher surface roughness. The technology combining machining with selective laser melting for metal powder forming process originally developed by the Panasonic Corporation (formerly known as the Matsushita Electric Industrial Co., Ltd.) is exactly the solution to make up for such shortcomings of conventional SLM technology. The composite technology combining machining with SLM integrates the layer-by-layer additive forming technology by selective laser melting (SLM) with conventional high-speed machining technology. It combines the two opposite manufacturing processes, the layer-by-layer additive forming process and the subtractive machining process, and integrates material technology, computer software technology, laser sintering technology and computer numerical control technology. In comparison with the layer-by-layer metal powder forming process realized by simple selective laser melting, this composite technology can be a one-time process for creating an integrated component with conformal cooling and air venting functions, such as high-precision molding parts with complex surface profiles that are difficult to perform follow-up machining processing on. The machining precision can be below  $\pm 0.005$  mm, and the hardness after heat treatment can be higher than Hrc 50. The cooling time of the mold components manufactured using this composite technology can be effectively reduced. In addition, the trapped air can be removed, so that the injection molding efficiency can be increased and the quality of the molded products can be improved. Therefore, this composite technology combining machining with SLM is particularly suitable for manufacturing high-precision molds for injection molding.

## Manufacturing Process of Composite Technology, Combining Machining and SLM for Metal Powder Forming

The Manufacturing process of this technology is shown in Figure 1. (1) The laser melts the metal powder spread on the metal base plate; (2) Repeat spreading the metal powder and laser melting for the layer-by-layer additive forming until the thickness reaches the effective cutting length of the tools; (3) Perform the cutting action on the side wall of the stacked layers with small-diameter tools; (4) Repeat the selective laser melting, layer-by-layer additive forming, and high-speed machining processes; (5) Eventually, a precise, three-dimensional surface profile of the machined work piece can be obtained. The difference between the conventional SLM technology and the composite technology combining machining and SLM can be distinguished according to Figure 2.

### Practical Application- Auxiliary Fuel Tank for Automobiles (60% Reduction in Cooling Time)

Figure 3 shows the components for the jet pump (JP) and overflow (OF) section of the auxiliary fuel tank used in automobiles which are manufactured using the composite technology combining machining and SLM for metal powder forming. Because the technology can incorporate conformal cooling channels inside narrow parts which are difficult to be cooled using the conventional manufacturing methods, the cooling time for the entire mold is reduced from an original 25 seconds to 10 seconds.

In addition, the accuracy of the dimensions of the plastic parts close to the round base and the snap fit are increased. (See Table 1)

	Evaluation Item					
	①		②		③	
	Steel (water)		Laser Sintering (water)		Laser Sintering (air)	
Cooling time	JP	SNAP FIT	JP	SNAP FIT	JP	SNAP FIT
	25	80	130	59	59	80
18	80	130	59	59	–	–
15	80	130	59	58	80	100
10	80	130	58	69	–	–

Table 1 Cooling performance evaluation

## Application of Moldex3D Molding Simulation Techniques for Design Verification of Conformal Cooling Channels

How conformal cooling channel designs may achieve the desired results, including reductions in cooling time and improvement of product quality, is often difficult to grasp before the mold trial. But with such tools as molding simulator, it is possible to verify the efficacy of the cooling channel design before mold manufacturing, thus achieving the goal of effective cost reduction.

Since we know that the ideal cooling system must take into account the distribution, type, fluid temperature, flow rate and cooling time for the fluid channels. An effective fluid channel design matches the fluid channel to the profile of the product, so as to achieve the goal of uniform heat removal. Figure 4 shows an example of a machinery chassis provided by the OPM laboratory. Due to the complex geometry of this product, the core side is designed with a total of two sets of cooling channels distributed close to the product surface. Figure 5 shows the differences between a conventional cooling channel design and the conformal cooling channel design. The Moldex3D was used to analyze the two cooling channel designs and then compare the results with the on-site data. According to the on-site ejection criterion provided by the OPM laboratory, there shall not be any shrinkage of the product surface. Under this criterion, the conformal cooling channels can have a cooling time 10 seconds less than that of a conventional cooling channel (Figure 6). Figure 7 shows the comparison of the sink mark displacement for the conventional cooling channel, with a 30-second cooling time, and the conformal cooling channels, with a 20-second cooling time. According to the results, the values and locations predicted by the software are very close to the on-site cases.

### Conclusion

In this article, the composite technology combining machining and SLM for metal powder forming and the application of conformal cooling channels are described. Compared with the layer-by-layer addition metal powder forming using conventional selective laser melting technology, the composite technology not only retains the advantages of flexible manufacturing capability but also has the advantage of high-speed and high-precision machining. It features a one-time manufacturing process for creating an integrated component with conformal cooling channels and air venting functions, which can even be a high-precision molding parts with complex surface profiles that are difficult to perform follow-up machining processing on. In addition, Moldex3D was used for analysis and comparison of the conventional and conformal cooling channel designs, and reasonable verification results were obtained. Moldex3D is an effective tool for design verification of cooling channels to reduce manufacturing costs.

**Keyword:** : metal powder, laser melting, layer additive, milling, conformal cooling, cooling time, venting.



**Author:** Yan Chin

**Tel:** +86-21-54423111

**Email:** [mmt-yq@matsui.com.cn](mailto:mmt-yq@matsui.com.cn)

## References

1. 阿部論等, 金属光造形複合加工システムによる高機能射出成形金型製作, 松下電気技術, Vol.53 No.2, p5-11
2. 不破勲等, 低密度層からなるガスベントを有する金属光造形金型, 松下電気技術, Vol.55 No.2, p17-22
3. 浅析金属粉末激光造型复合加工技术, 塑胶及金属, 2011 年第 2 期, p26-27

In appreciation of OPM Laboratory Co.,Ltd. to provide images and statistics.

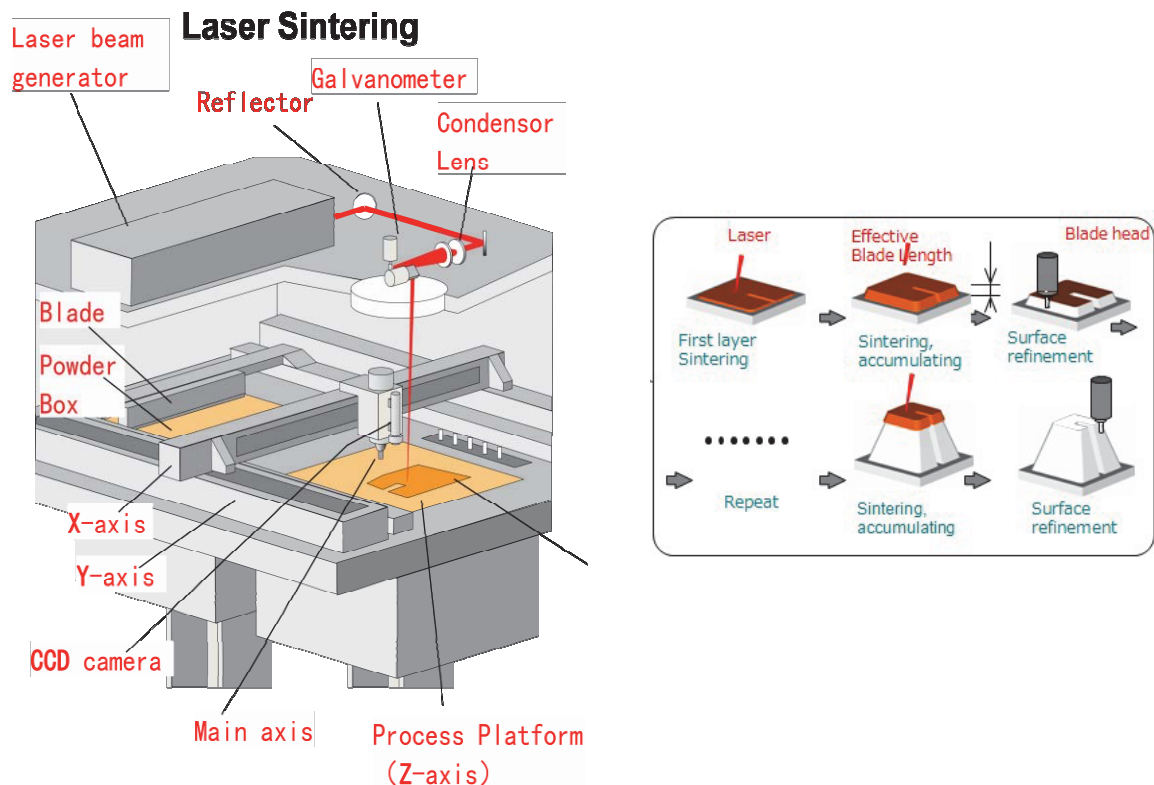
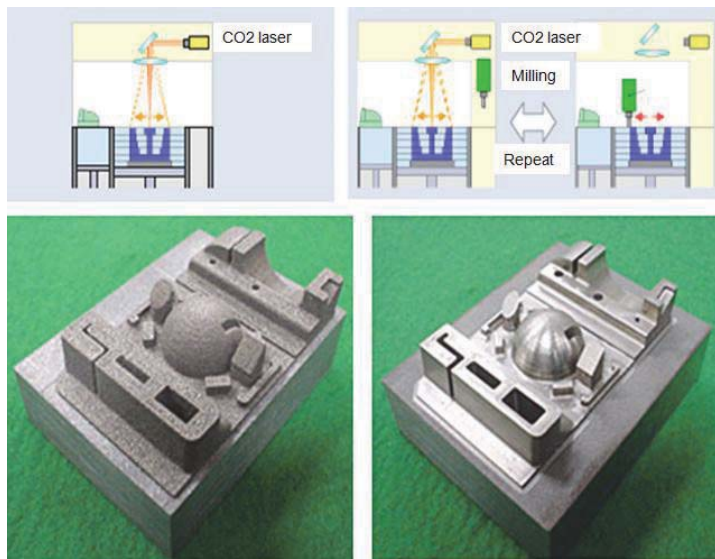

Figure 1 Laser sintering facilities and processes



(A) (B)

Figure 2 SLM technology (A) and hybrid technology (B) comparison

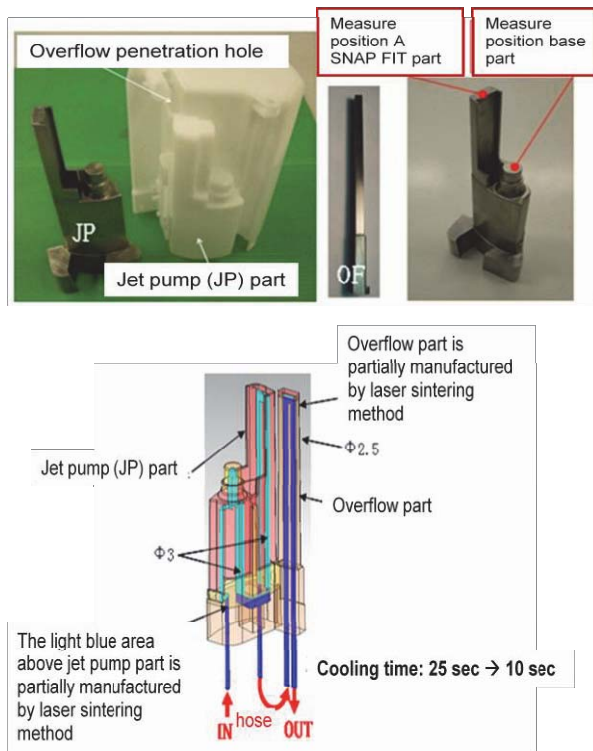

Figure 3 Auxiliary gas tank cooling improvement case

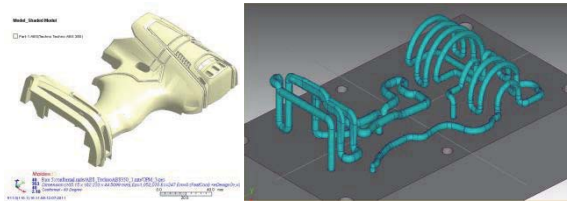
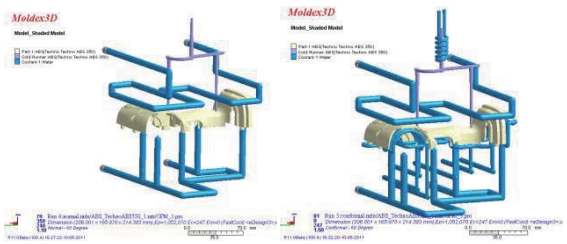

Figure 4 Machine tool cover model and conformal cooling design



(A) (B)

Figure 5 Conventional (A) and conformal cooling (B) design



(A) (B)

Figure 6 (A) Conventional and conformal design cooling time comparison (B) Sink mark location

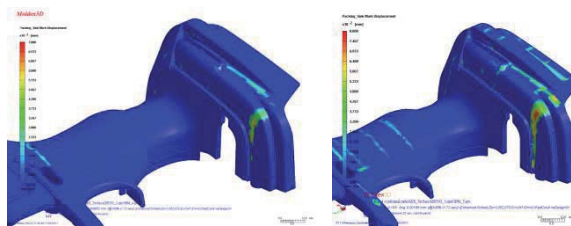

(A) (B)

Figure 7 Sink mark displacement comparison (A) Conventional cooling (B) conformal cooling

## 3D Cooling Channel Import is Now Available in R11.0

Starting from Moldex3D R11.0, it is possible to predict coolant properties inside 3D cooling channels and to simulate non-circular cross section cooling channels in eDesign. New Moldex3D R11.0 provides numerous enhancements and improvements to 3D cooling channel functionalities to help design better cooling systems effectively.

### Support for 3D cooling channel import (eDesign projects)

Moldex3D Designer offers a very intuitive way to build 3D cooling channels for eDesign projects. The procedures to import a 3D cooling channel are as easy as follows:

#### 1. Import the cavity and the runner model.

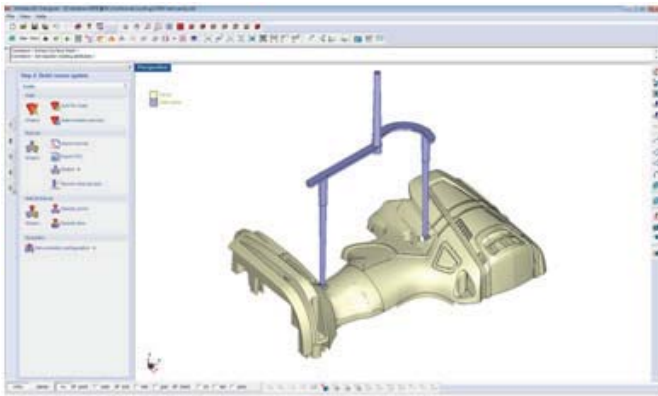

2. For the 3D cooling channels, just click the “import” icon. The supported file formats are .stl, .iges, and .stp. If the file is not a surface mesh file (i.e. .stl file), the program will extract the surface automatically. Remember to assign the attribute to “cooling channel”

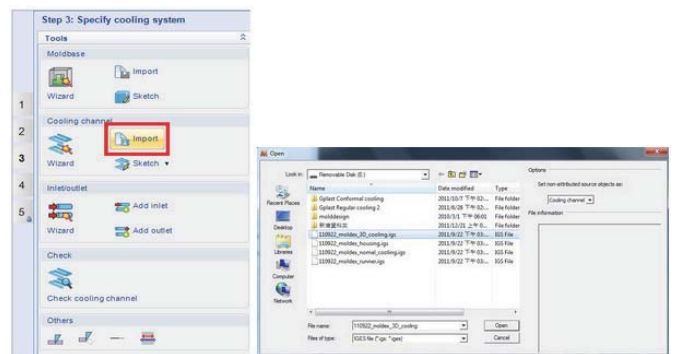

3. The imported cooling channels are shown in blue in the picture below. Now, you can easily create a non-circular cooling channel in eDesign. The remaining steps to defining the model are the same as usual.

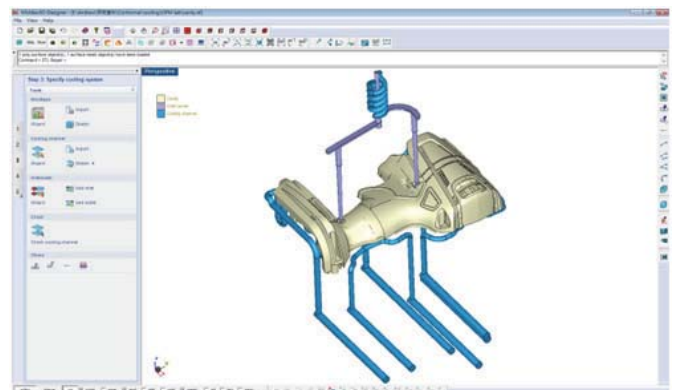

## 3D Coolant Property Prediction (Solid Projects)

On the other hand, Moldex3D Mesh provides a very flexible way to build complex cooling systems for Solid projects. The steps are as follow:

### 1. Create cooling system mesh.

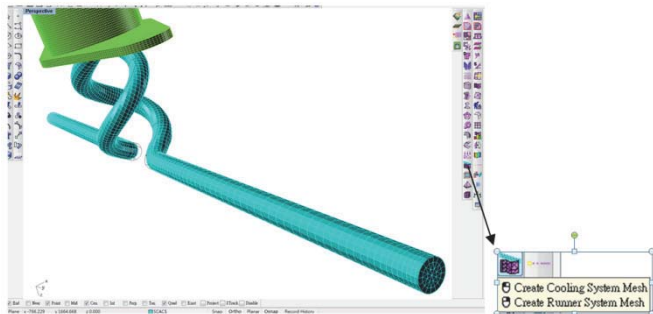

### 2. Export Solid Model.

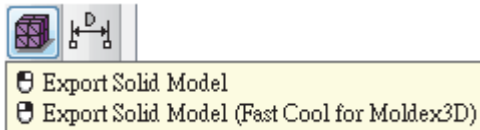

3. In Moldex3D process settings, under "computation parameter", set the "Cooling channel analysis by" to "Run 3D solid cooling channel analysis."

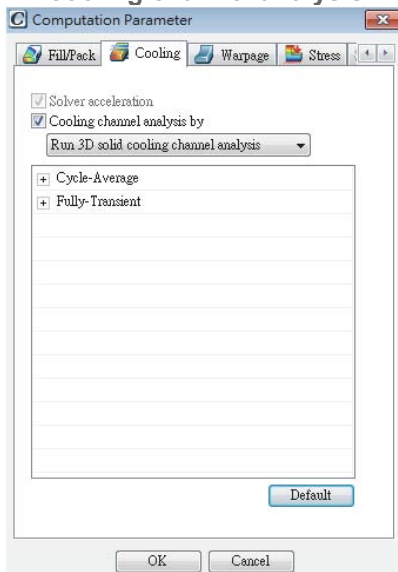

4. Additional results such as coolant pressure, temperature, velocity can be found in the cooling result.

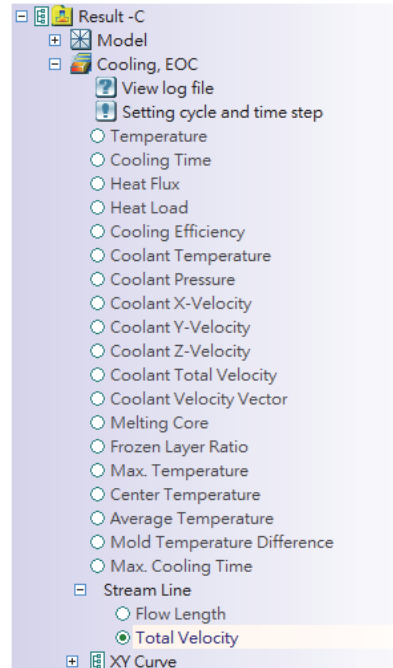

## Maximizing Cooling Effects with Moldex3D Conformal Cooling Solution- A Case Study of MATSUI MFG. CO., LTD.



**A Case Study of MATSUI MFG. CO., LTD.**

This case study aims to compare the cooling effect of conformal cooling with the normal cooling design. As shown in the figure below, this model has a very complex geometry. Also, thickness variation is large. With conformal cooling channel design, cooling time was dropped by 10 seconds (33%).

Traditionally, cooling channels cannot be made along with the product geometry, so that the cooling efficiency is limited, especially for those products with complicated geometry. Nowadays, the advanced manufacturing technology has made the conformal cooling possible, However, the verification and optimization of the cooling channel design become more and more difficult because of the complex geometry.

Moldex3D Cooling Analysis can help determine not only the required cooling time, but also the temperature variation inside the mold. Moreover, the coolant behavior such as coolant flow rate, pressure loss, vortex/dead water area can further be estimated by Moldex3D 3D Cooling Channel Analysis. Therefore, it's no longer a problem to optimize the conformal cooling channel design, so as to improve the cooling efficacy.

So what Moldex3D can help in conformal cooling are:

- Increase cooling efficiency. With conformal cooling, cooling rate difference can be minimized through the whole part.
- Reduce cycle time and cost.
- Create better product quality.

First of all, the dimensions of the product is as follows:

- Length:162.23 mm
- Width:105.15 mm
- Height: 44.51 mm
- And the major thickness is around 3 mm

In this study, we are going to compare the cooling efficiency between the conventional cooling design and conformal cooling design. The conventional cooling design has baffle design in the core side, while the

conformal cooling design has cooling channels tightly fit to the product geometry.

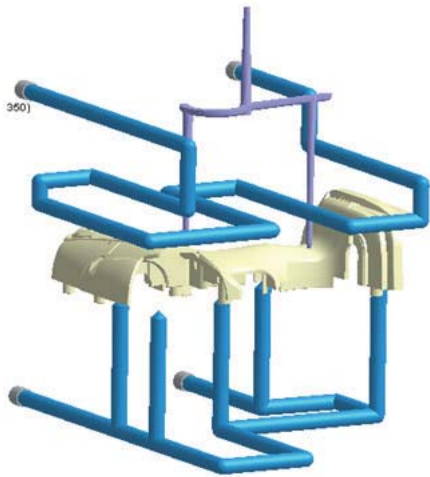

a. Conventional cooling design

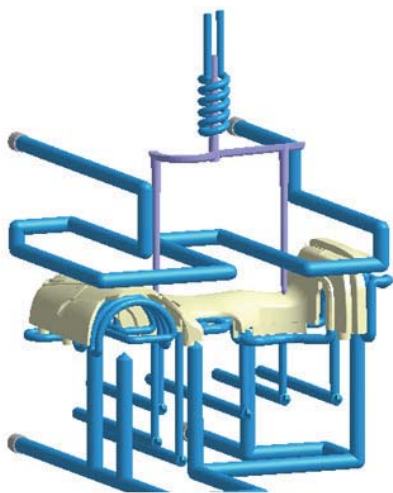

b. Conformal cooling design

The conformal cooling layout was drawn with same normal distance from the cavity surface to pipe. However, due to geometry limitation, there are still some places unable to locate the cooling lines. The average cooling channel diameter is 4mm; the distance from cavity surface to pipe center is 8.3mm; and the distance between pipes is 9mm.

Here below are the simulation results of these designs:

For the conventional design, the Part surface temperature distribution at the end of cooling is shown as below. The temperature range is from 60.04 – 134.02 °C. The cavity side has a low and quite uniform temperature distribution; however, at the core side, the part surface temperature differs from area to area. The highest temperature area is indicated by the red circle. It is obvious that no cooling channel go through this area.

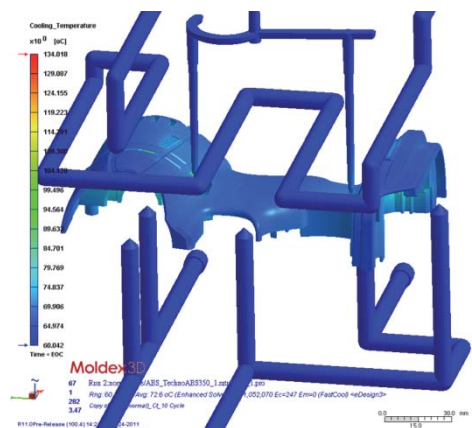

a. surface temperature is around 57.82 – 129.95 °C

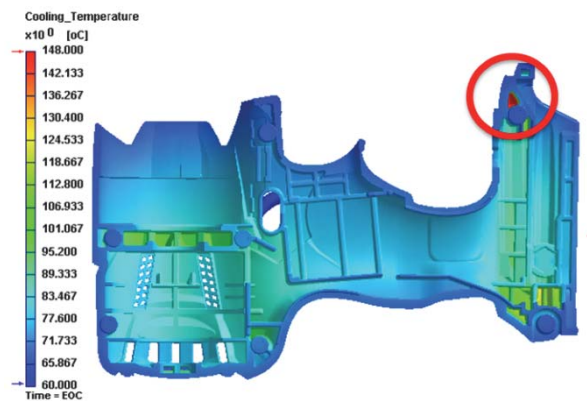

b. Highest temperature is shown in red circle.

Below is a figure showing the required cooling time for the indicated area. The cooling time is defined as the time needed to cool down to the ejection temperature since the end of packing (EOP). As the value estimated is around 101.55 sec, the default cooling time (20sec) may not be enough.

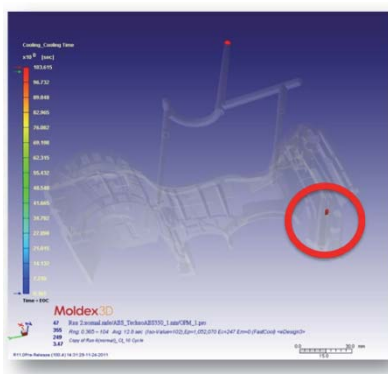

For the conformal cooling, the part surface temperature distribution at the end of cooling is shown as below. The temperature range is from 57.82 - 129.95 °C, which is lower than the conventional design. Besides, it can be seen that the temperature distribution at the core side are more uniform that in the conventional design.

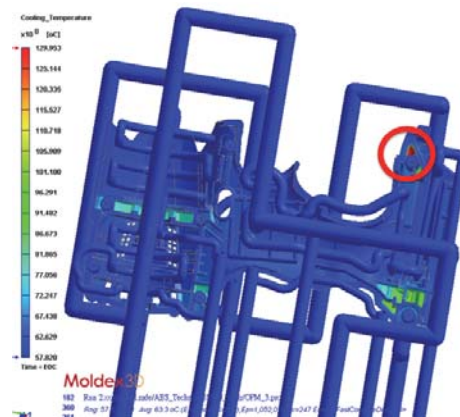
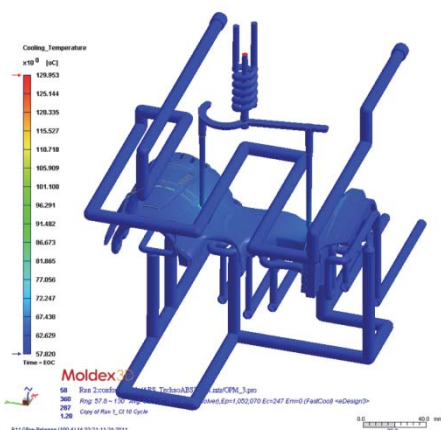

In terms of cooling time, the Max. cooling time required is also reduced to 96.51 seconds.

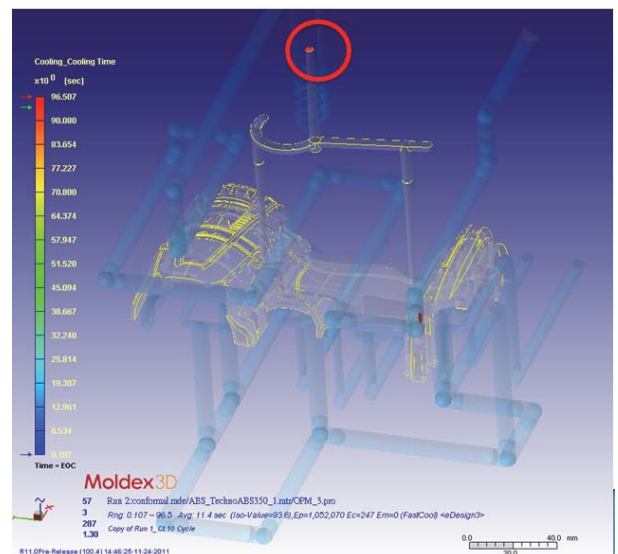

If we set the same temperature range for the two cases, we can see that conformal cooling effectively remove most of the heat from the core side. However, the max. temperature area still exists since no cooling channel pass that area (red circles).



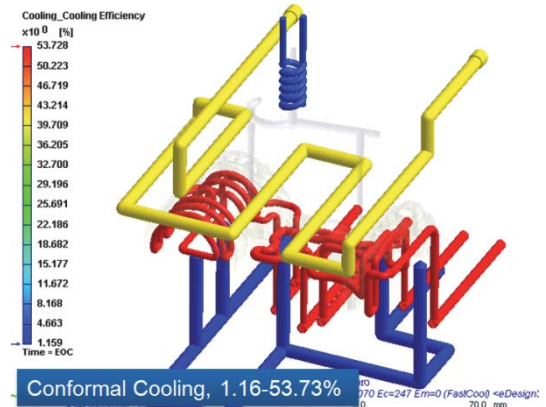
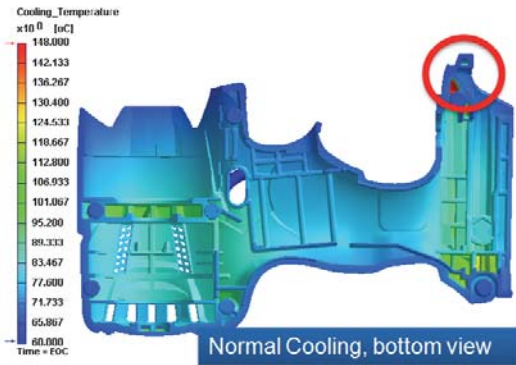

Below is the cooling efficiency comparison. In the conventional design, since the baffle does not reach the core side of the part, the lower cooling channel only absorbs 1/3 of the total heat. On the other hand, in the conformal cooling design, the conformal cooling channel has the highest efficiency (53.73), and conversely, the baffle cooling channel has a very low efficiency (1.16%)

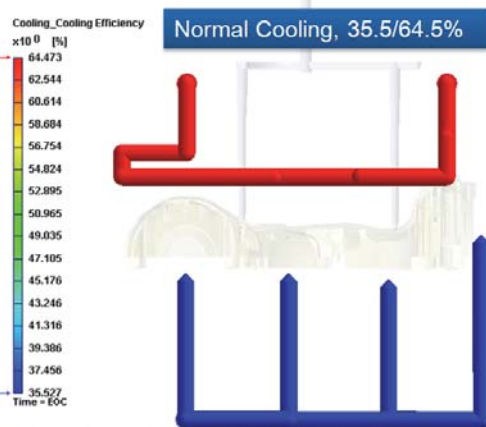
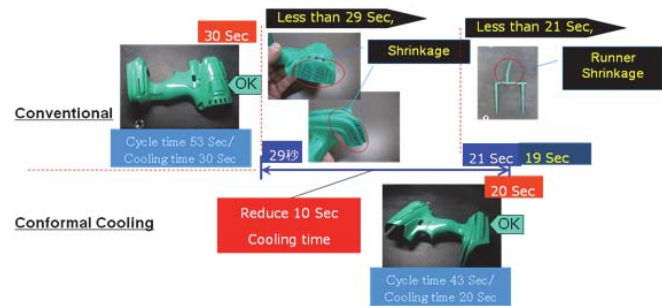

The cycle time is also an important issue to be concerned in the cooling design. Compared to the conventional design, the conformal cooling can reduce 10 sec cycle time, or 33 %, while keeping the same product quality.

For instance, the sink mark can be used as an index for the product quality. Below are the sink mark comparison of the conventional design with 30 seconds cooling time and the conformal cooling design with 20 seconds cooling time. We can see that the sink mark values at the indicated areas are quite the same in these two cases (Normal: 0.07mm; Conformal: 0.08mm).

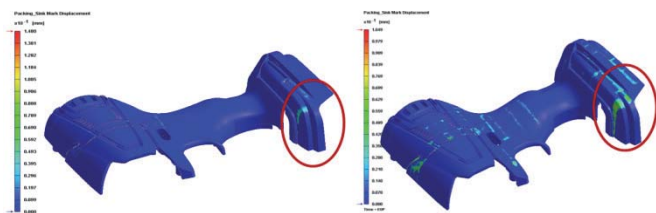

Displacement 0-0.148mm

Displacement 0-0.105mm

In summary, the cooling efficiency of the conventional cooling design is limited, and hard to be improved further because the cooling channel cannot reach to the product surface. In this case, we can see that the conformal cooling design can effectively lower cooling time and improve the cooling efficiency while maintaining product quality. Moldex3D offers a useful tool to help users accurately predict the effects on conformal cooling design.

## Synergy of True & Full 3D Simulation and Conformal Cooling

### Key Benefits

- › Warpage Improvement.
- › Cycle time reduction: about 400,000 seconds are saved annually and productivity enhancement.
- › Long-term unsolved quality deviation is fully resolved.
- › Recycling of cooling fixture is eliminated and profitability is enhanced.

This case study aims to compare the cooling effect of conformal cooling with the normal cooling design. As shown in the figure below, this model has a very complex geometry. Also, thickness variation is large. With conformal cooling channel design, cooling time was dropped by 10 seconds (33%).

With the more and more challenging marketing and customer demands, technologies which can ensure the better quality, cost performance, time to market...and etc., are always what we would absolutely look for. This is the same for the injection molding industry — As we know, the cooling time often occupies of 70% of the injection cycle and critical for most of the warpage issues. When process optimization and quality improvement is a priority, we always try to find some lights in this cooling stage.

The customer of this successful case study, Gplast, is from Coimbatore, India. With more than three decades of experience and expertise in Tool and Die making, injection molding and die casting, Gplast is very well known for its achievements in Electronics, Precision Machine Tools and Transport.

Warpage is the first priority since product quality is affected a lot. However, due to the geometric limitation, revising process conditions or other efforts could not really lead to satisfying enhancements. Since conformal cooling is one of the key advantages of Gplast, it is decided to use the true and full 3D Computer Assisted Engineering (CAE) tool to evaluate the effectiveness of the customized cooling layout designs.



Fig. 1. Cooling channels and mold base – true 3D mesh model for simulation accuracy

One of the important concerns in this case is – the traditional 1D runner or cooling layout is not capable for simulating correct results due to theoretical and functional limitations.

After using Moldex3D/Solid for complete simulation of the original cooling layout design, the analysis result shows the internal temperature is quite high and there is a region with heat accumulation. The mold temperature difference results in the non-uniform shrinkage – finally it leads to the warpage problem which is related with thermal effect.

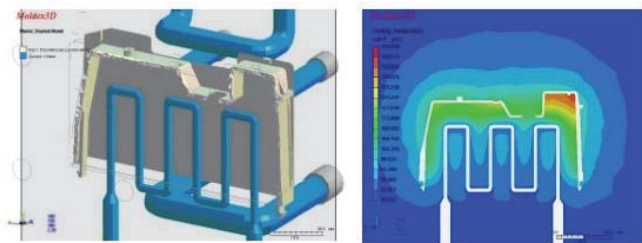

Fig. 2. Original cooling layout (left) and the mold temperature difference (right)

To improve this warpage problem, conformal cooling design is applied for solutions. Moldex3D is again used for performing reliable analysis via complete and high-performance 3D simulations. After revising the cooling system, the mold temperature difference is greatly reduced from 40°C to 6°C – about a 85% improvement. In addition, the temperature of the corner region (with exceeding heat in original design) is much more uniform.

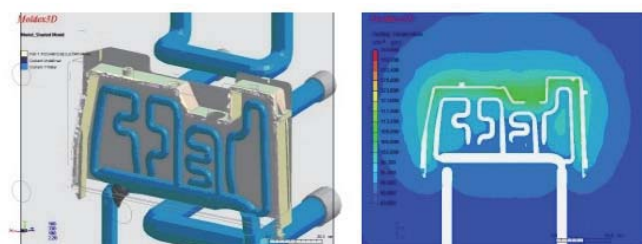

Fig. 3. Revised cooling layout (left) and the mold temperature difference (right)

Compared with the original design, the Z-displacement of the revised cooling system is reduced 25.6%. The target of the cooling system optimization is successfully reached by such an outstanding warpage improvement. In this case, Moldex3D simulation results are highly consistent with the real injected parts, and prove

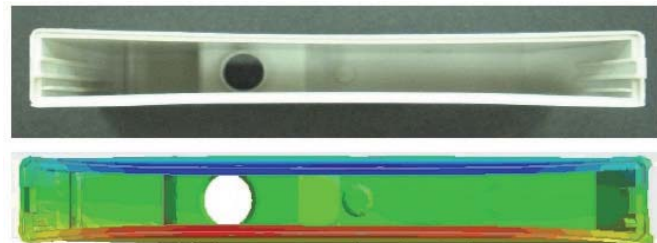

Fig. 4. Warpage of original design – real injected part and simulation result



Fig. 5. Warpage results of revised design with conformal cooling –real injected part and simulation result

## Behind the Scene

This is just one of many successful cases done in Gplast. The synergy of true 3D Simulation and conformal cooling design capability proves not only the quality issues like warpage can be effectively eliminated, but also the product development cycle time would be improved. The true 3D Simulation plays an important role – assists to identify the connections between revised cooling designs and the results. Without these

analysis results, it would be difficult to precisely evaluate the contribution of different conformal cooling layouts. The application of Moldex3D brings the real confidence for both product development and the performance of conformal cooling designs.

In short, the real performances of this case include:

- › Warpage Improvement
- › Cycle time reduction (Annual: about 400,000 seconds are saved) and productivity enhancement
- › Long-term unsolved quality deviation is fully resolved.
- › Recycling of cooling fixture is eliminated and profitability is enhanced.



One of the fundamental reasons for choosing Moldex3D in spite of being a customer to other CAE tools in the market was that we were looking for a professionally true and full 3D

customized solution in terms of analysis and who can be a strong partner working with us in providing the best solutions. After these successful cases, we feel that Moldex3D is truly supporting for conformal cooling, and the effectiveness is satisfying. In addition, the technical support and service quality of EUC Tech and CoreTech teams is very impressive and far beyond our expectations! We are glad that we made the right decision. (Mr. G.D. Rajkumar, the Director of Gplast)

## About Conformal Cooling

Conformal cooling is defined as the ability to create cooling / heating configurations within a tool that essentially follows the contour of the tool surface or deviates from that contour as thin / thick sections of the part may dictate for optimal thermal management. The objective typically is to cool or heat the part uniformly. Conformal cooling provides a tremendous advantage in mold tooling through significant reductions in cycle times. Other than the obvious piece-cost savings, other tangible benefits include tool, equipment and floor space savings. (Source: Gplast)

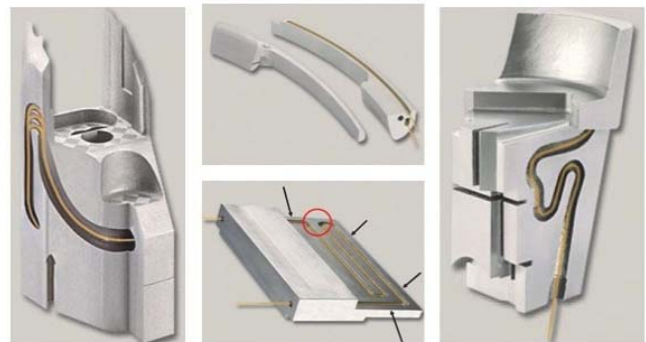

Service Provider: EUC TECH

User: G-Plast (P) Ltd

- |   |   |
|---|---|
| › No. 52A, (Old No.4), 2nd Avenue, Ashok Nagar, Chennai-600 083, INDIA. | › GOPAL BAGH, 1065, Avinashi Road, Coimbatore – 641 018 Tamil Nadu, INDIA |
| › Tel : +91 44 42065044   | › Tel : + 91 – 422 – 2243798  |
| › Fax : +91 44 24743714   | › Fax : + 91 – 422 – 2242760  |
| › <a href="http://www.euctech.com">www.euctech.com</a>                  | › <a href="http://www.gplast.com/">http://www.gplast.com/</a>             |